

MA3100 Series

Cost effective surge protection designed to cope with high magnitude 10/350µs current waveforms as described in IEC 61312

- **Space saving design, DIN rail mounting**
- **IEC Class I, II and III products available**
- **Single pole Ipeak of 60kA (10/350µs) for Class I devices**
- **Multiple pole Ipeak of >100kA (10/350µs) for Class I devices**
- **Full range of AC mains power applications**
- **Coordinated surge protection to IEC 61312; rated according to IEC 61643**



The MA3100 Series offers cost effective surge protection for applications described by IEC 61312 where the surge protector could carry a partial share of the lightning surge current. The MA3100 Series fulfills IEC's cascade protection philosophy. Class I devices rated for 60kA (10/350µs) are deployed at the service entrance, followed by the Class II rated devices at key power panels. Sensitive systems can then be locally protected by a Class III device.

All modules are DIN rail mounted for ease of installation and have very small footprints therefore minimising the space required. Even the powerful 60kA (10/350µs) single pole module is only 18mm wide. Each device is simply connected in parallel with the power system via a fused spur.

The Class I lightning current arrester offers a very high performance specifica-

tion. The unit withstands the impact of a 60,000A impulse with a lightning wave-shape of 10/350µs with a specific energy of 1,000kJ/Ω. These levels are significantly higher than called for in IEC 61643 for a Class I device.

The Class II surge current arrester is designed to work as both a standalone device and in cascade coordination with MTL's Class I lightning arrester. A single width module withstands surge currents up to 45,000A with an 8/20µs waveform. Class II arresters are available in single width modules for maximum user flexibility, double width modules for all-mode protection on single phase systems and quad width modules for all-mode protection on three phase systems. Many Class II modules have remote monitoring capabilities as a standard feature. Voltage free, normally open, normally

closed contacts can be used for a variety of monitoring tasks.

The Class III surge protector is designed to protect individual pieces of equipment. A typical example of a Class III device is the MA15 which offers RFI/EMI filtering in addition to excellent levels of surge protection.

Coordinated IEC 61643 Class I, Class II and Class III surge protection

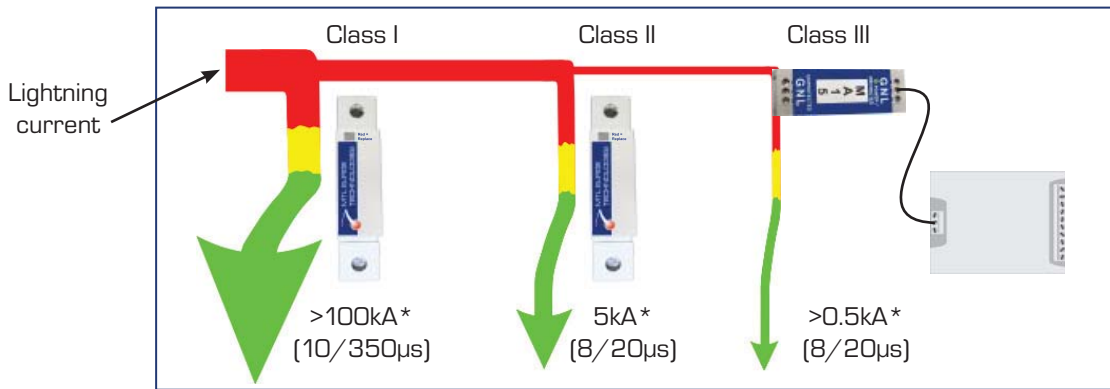

*Total over a 3 phase system.

The MA3100 range offers cost effective surge protection for applications described by IEC 61312, where the AC mains supply can carry a partial share of the lightning surge current. Class I surge protectors (rated according to IEC 61643) are designed to carry up to 60kA (10/350 μs). Class II surge protectors are characterized by their ability to protect against 8/20 μs impulses up to 45kA, possibly resulting from the operation of a class I device. Finally Class III devices are used to protect individual pieces of equipment. An excellent example of a class III device is the MA15.

TN-C-S System

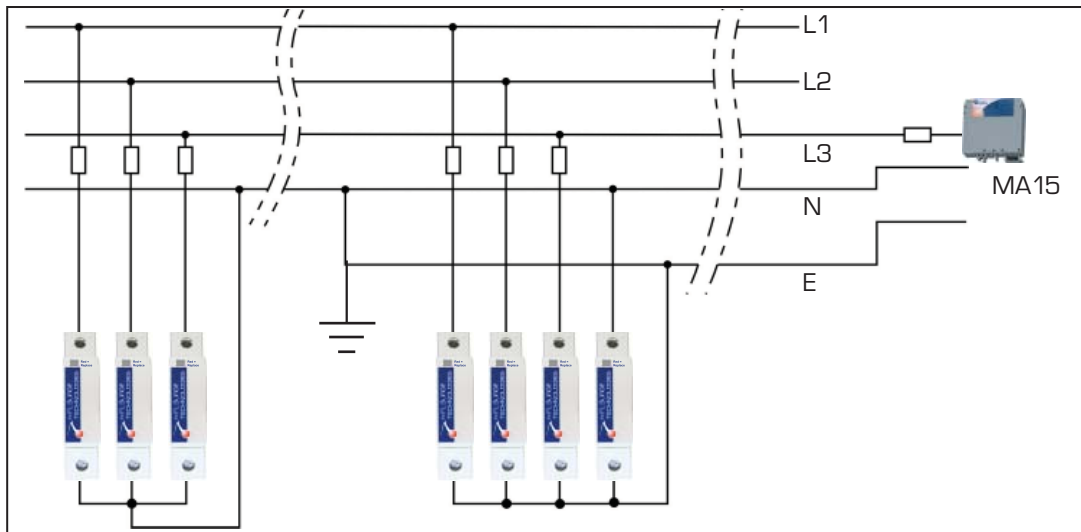

Variations for IT

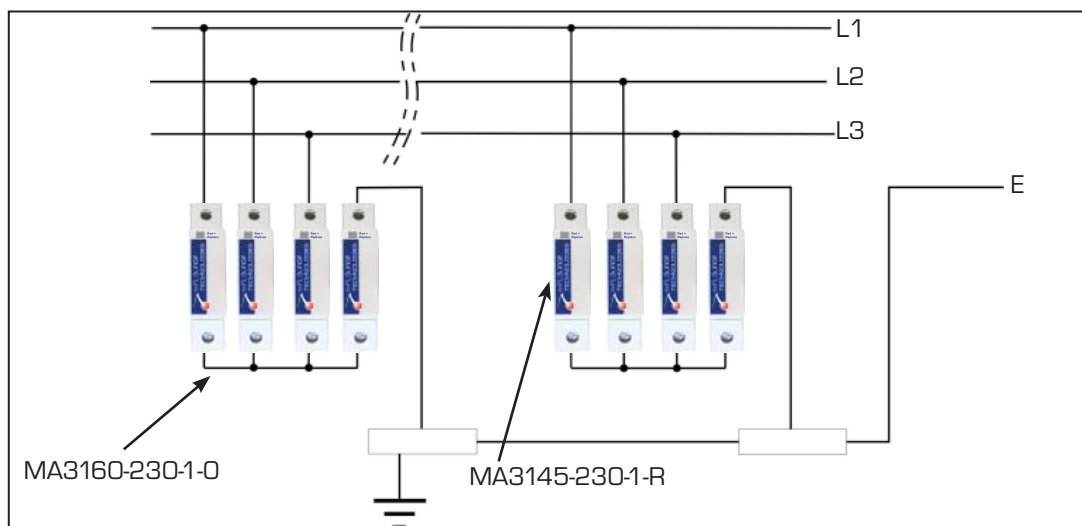

Variations for TT

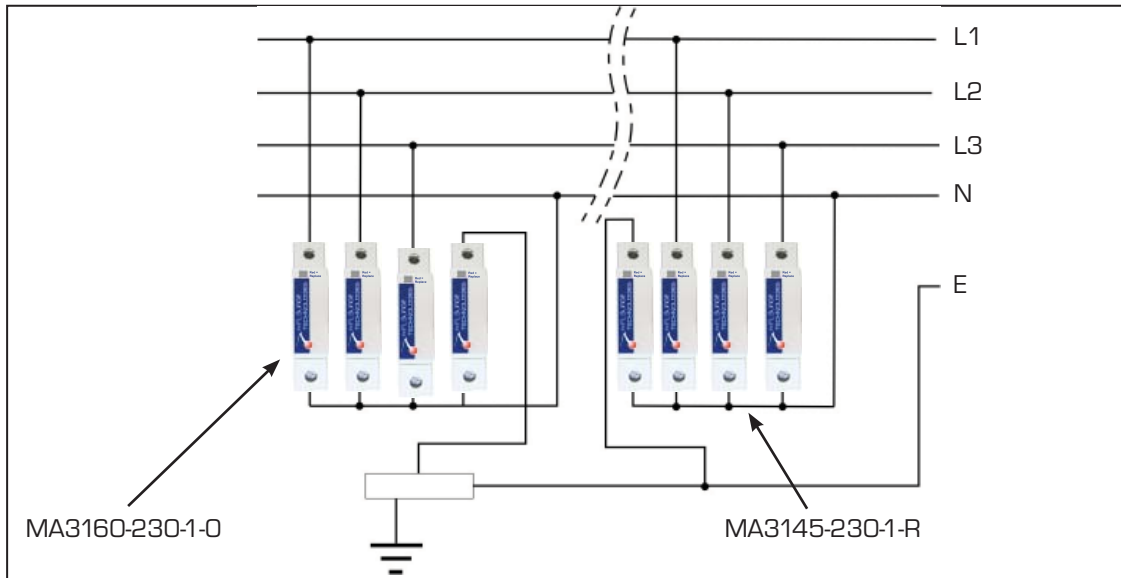

Class I Surge Protection Device

Technical data	MA3160	230-1-0
Dimensions (see Fig. 1 for A, B and C)		A
IEC category/VDE requirement class:		I/B
Max. continuous operating voltage U_C :		250V 50/60Hz
Leakage current:		<1 μ A
Lightning test current I_{imp} (10/350 μ s)	peak value/charge: 2 & multi-pole specific energy:	60kA/30As >100kA/>50As 1000kJ/ Ω
Protection level U_p :		\leq 4kV
Response time t_a :		\leq 100ns
Quenching short circuit current I_f :		1.5kA/250V
Max. required backup fuse:		125A gL
Climate category:		-40°C to +80°C
Perm. relative air humidity:		\leq 95%
Protection type acc. to IEC 60 529/EN 60 529:		IP20
Maximum wire size:		25mm ²
Torque:		4.5Nm
Inflammability class in acc. with UL94:		VO
Test standards:	IEC 61643-1:1998-02 E DIN VDE 0675 PART 6:1989-11/A2:1196-10	

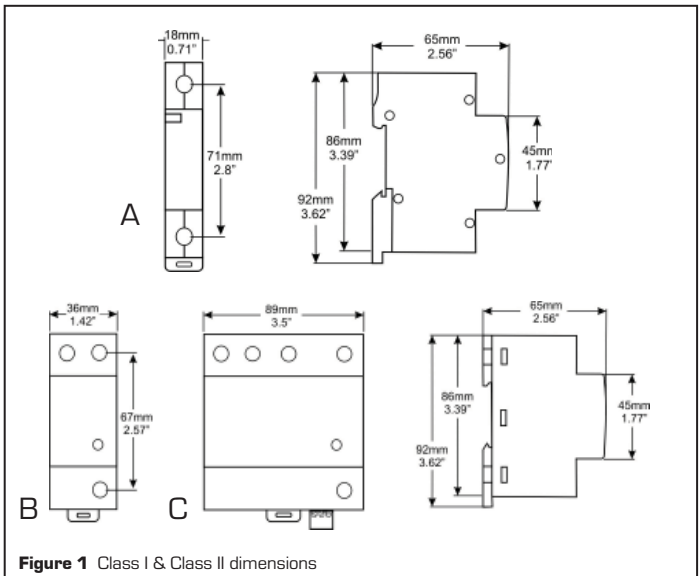

Figure 1 Class I & Class II dimensions

Class II Surge Protection Device

Technical data	MA3145	120-1-R	230-1-R	120-2-0	230-2-0	120-4-R	230-4-R
Dimensions (see Fig. 1 for A, B and C)		A (1 pole)	A (1 pole)	B (2 pole)	B (2 pole)	C (4 pole)	C (4 pole)
IEC category/VDE requirement class:		II/C	II/C	II/C	II/C	II/C	II/C
Nominal voltage U_n :		120V AC	230V AC	120V AC	230V AC	120/208V AC	230/400V AC
Max. continuous operating voltage U_C :		150V AC	270V AC	150V AC	270V AC	150V AC	270V AC
Lightning test current I_{imp} (10/350 μ s)		—	—	—	—	—	—
peak value/charge: specific energy:		—	—	—	—	—	—
Leakage current to PE at U_n :		\leq 0.3mA	\leq 0.3mA	\leq 0.3mA	\leq 0.3mA	\leq 0.3mA	\leq 0.3mA
Nominal discharge surge current I_n (8/20 μ s):		10kA	10kA	10kA	10kA	10kA	10kA
Max. discharge surge current I_{max} (8/20 μ s):		45kA	45kA	45kA	45kA	45kA	45kA
Protection level U_p :		<690V	<1.3kV	<690V	<1.3kV	<690V	<1.3kV
Residual voltage at 5kA:		490V	900V	490V	900V	490V	900V
Response time t_a :		\leq 25ns	\leq 25ns	\leq 25ns	\leq 25ns	\leq 25ns	\leq 25ns
Max. required backup fuse:		125A gL	125A gL	125A gL	125A gL	125A gL	125A gL
Remote indication contact:							
max. perm. operating voltage U_{max}		20V AC/20V DC	20V AC/20V DC	none	none	125V AC/110V DC	125V AC/110V DC
max. perm. operating current I_{max}^{AC}		20mA	20mA	—	—	0.3A	0.3A
max. perm. operating current I_{max}^{DC}		20mA	20mA	—	—	0.3A	0.3A
Temperature range:		-40°C to +80°C	-40°C to +80°C	-40°C to +80°C	-40°C to +80°C	-40°C to +80°C	-40°C to +80°C
Protection type acc. to IEC 60 529/EN 60 529:		IP20	IP20	IP20	IP20	IP20	IP20
Inflammability class according to UL94:		VO	VO	VO	VO	VO	VO
Stripping lgth: Biconnect term. blks./remote indicator contact:		14.5/7mm	14.5/7mm	14.5/7mm	14.5/7mm	14.5/7mm	14.5/7mm
Torque: Biconnect term. blks./remote indicator contact:		4.5Nm/0.25Nm	4.5Nm/0.25Nm	4.5Nm/0.25Nm	4.5Nm/0.25Nm	4.5Nm/0.25Nm	4.5Nm/0.25Nm
Approvals:							
Test standards:	UL1449; IEC 61643-1:1998-02						

To order Class II surge protection devices, specify -

MA31 45 230 1 O/R

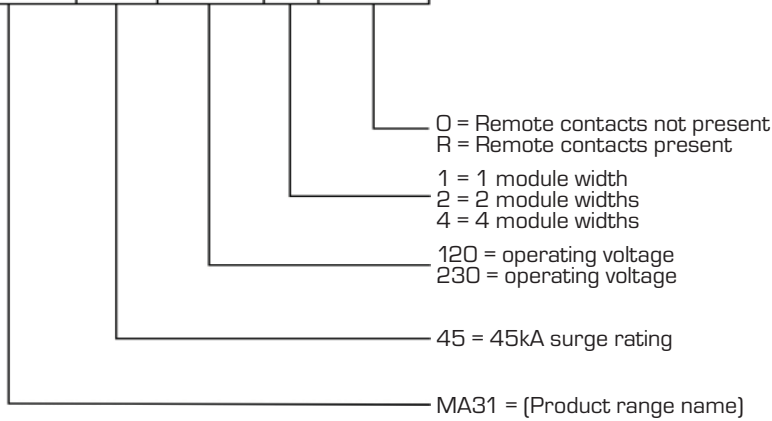

Class III Surge Protection Device

The MA15 Series of surge protection devices has a unique 'three stage' combination of protection elements, that suppress conducted RFI and voltage surges. The current elements are first, surge clipping components to absorb transient surges that may otherwise damage equipment, second a filter to suppress noise in the system and third, 'ring' suppression. The third of these prevents surges causing the filter to 'ring' (oscillate) under low load conditions – an effect that actually accentuates interference in most commercially available filters.

The MA15 Series protects electronic equipment and computer networks against the effects of 'noise pollution' induced in power supplies. MA 15 units 'clean up' the effects of industrial noise and surges caused by lightning, switching devices, thyristor controls, transmission system overloads and power-factor correction circuits.

MA15 Series

MA15 technical data	MA15D1	MA15D2
IEC category/VDE requirement class:	III	III
Nominal voltage U_n :	120V AC	230V AC
Max. continuous operating voltage U_c :	150V	275V
Max. load current $I_n/40^\circ\text{C}$:	15A	15A
Leakage current to PE at U_n :	<0.3mA	<0.3mA
Nominal discharge surge current $I_n(8/20\mu\text{s})$: sym/asym	3kA/6kA	3kA/6kA
Maximum discharge surge current $I_{max}(8/20\mu\text{s})$: sym/asym	18kA/36kA	18kA/36kA
Protection level U_p :	400V/400V	1,000V/1,000V
Response time t_a :	<1ns/<5ns	<1ns/<5ns
RFI attenuation (50Ω):	-55dB @ 100MHz	-55dB @ 100MHz
Maximum required backup fuse:	15A	15A
Temperature range:	-40°C to +85°C	-40°C to +85°C
Protection type accordance to IEC 60 529/EN 60 529:	IP20	IP20
Inflammability class in accordance with UL94:	V2	V2
Stripping length:	8mm	8mm
Thread/Torque:	M3/0.8Nm	M3/0.8Nm
Approvals:	 Hazardous locations Class I Div 2 Groups A, B, C and D	

