

# AirGuard FGT Series



RF surge protection for the fixed wireless market with applications for LMDS, WLL, and MMDS.

- **Weatherproof**
- **Rugged construction**
- **Economic protection**
- **Versatile up to DC - 2.5GHz**
- **Allows DC/LF injection**
- **Multiple strike capability**



**The FGT Series** of surge protection devices prevents surges and transient overvoltages conducted through coax cables used for wireless Local Multipoint Distribution System (LMDS), Wireless Local Loop (WLL), and Multichannel Multipoint Distribution Service (MMDS). These versatile products can be used in any "F" connector application from DC - 2.5GHz frequencies to 75 ohm impedance.

**Typical applications for the FGT Series** include the protection of radio telemetry systems, mobile communications base stations and where high induced voltages may be present.

**Receivers and transmitters** are particularly vulnerable to damage from the effects of lightning. Their remote locations (height above ground) and physical construction make them vulnerable to lightning activity. The use of semiconductors and integrated circuits in transmitters and receivers has rendered them

particularly prone to damage from these disturbances.

**Excellent performance levels** are achieved using high energy gas discharge tubes to offer high surge current capability in a rugged, economic, compact enclosure to produce superior surge suppression.

**The use of gas tube technology** in surge protection applications is a mature and well proven technology. When used in RF coax applications, this technology provides broadband, low cost solutions while still maintaining high surge current capacity.

**Complete site protection** can be achieved by using MTL Surge Technologies' wide range of AC and DC power surge protection devices to prevent surges entering equipment  
v i a

their power supply. The ZoneMaster range of protectors combine a high level of protection and when used in conjunction with the ZoneBarrier data protection modules, provide the highest level of site protection available.

## RF Coax Protection

# Specification

All figures typical at 77°F (25°C) unless otherwise stated

**Maximum discharge current**  
20kA (8/20μs)

**Maximum power rating (VSWR)**  
1.5:1 @ 1.5GHz

**Frequency Range**  
DC to 2.5GHz

**Peak Pulse Current (8/20μs)**  
15kA - 20kA

**Impedance**  
75 Ω

| Model   | Connectors                                      | Frequency Range (GHz) | VSWR             | Insertion Loss (dB) | Peak Pulse Current (8μs x 20μs) | Impedance (Ω) |
|---------|---|-----------------------|------------------|---------------------|---------------------------------|---------------|
| RF51069 | F(f) Bulkhead to F(f)<br>(for LMDS/RG 6 Cable)  | DC - 2.5              | 1.5:1<br>@1.5GHz | .4                  | 20kA                            | 75            |
| RF51070 | F(f) Bulkhead to F(f)<br>(for LMDS/RG 59 Cable) | DC - 2.5              | 1.5:1<br>@1.5GHz | .4                  | 20kA                            | 75            |

| Model   | Connectors            | Frequency Range (GHz) | Return Loss (dB) | Insertion Loss (dB) | Peak Pulse Current (8μs x 20μs) | Impedance (Ω) |
|---------|-----------------------|-----------------------|------------------|---------------------|---------------------------------|---------------|
| RF51072 | F(f) Bulkhead to F(f) | DC - 2.5              | -18              | .03                 | 20kA                            | 75            |
| RF51073 | F(f) Bulkhead to F(f) | DC - 1.0              | -20              | .1                  | 15kA                            | 75            |

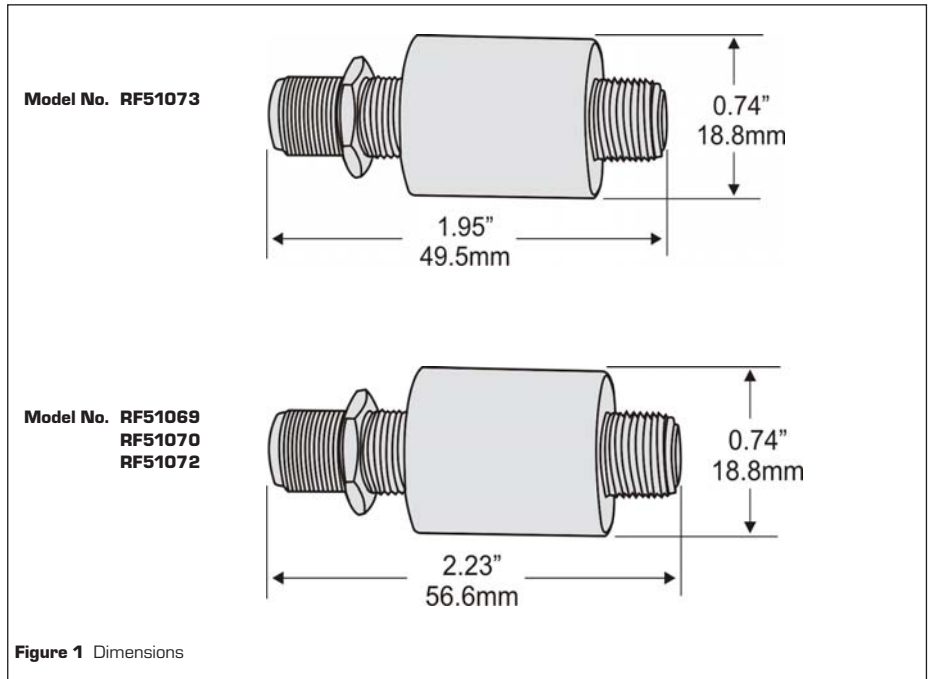

## Brackets

| Model   | Connectors | Diameter        |
|---------|------------|-----------------|
| RF51076 | F          | 0.385" (0.98cm) |

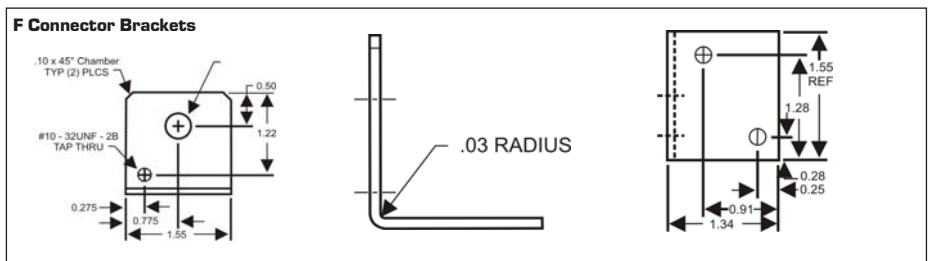

Note: In accordance with our policy of continuous improvement, we reserve the right to change the product's specification without notice.