







Cable to steel surface and pipe

CS1

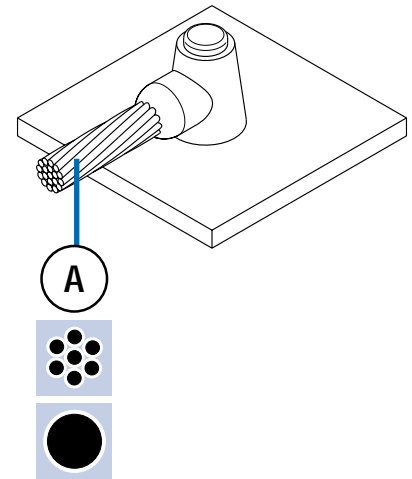
A mm ²			
16 25 35		USE CS8	
8mm Ø	90P10	CS1-4-8SC	HCPK4
50	90P10	CS1-4-50	HCPK4
10mm Ø	90P10	CS1-4-10SC	HCPK4
70	90P10	CS1-4-70	HCPK4
95	115P10	CS1-4-95	HCPK4
120	115P10	CS1-4-120	HCPK4
150	150P10	CS1-4-150	HCPK4
185	200P10	CS1-4-185	HCPK4
240	200P10	CS1-4-240	HCPK4
300	250P10	CS1-4-300	HCPK4



CS2

A mm ²			
16 25 35		USE CS9	
8mm Ø	90P10	CS2-4-8SC	HCPK4
50	90P10	CS2-4-50	HCPK4
10mm Ø	115P10	CS2-4-10SC	HCPK4
70	115P10	CS2-4-70	HCPK4
95	115P10	CS2-4-95	HCPK4
120	150P10	CS2-4-120	HCPK4
150	200P10	CS2-4-150	HCPK4
185	250P10	CS2-4-185	HCPK4
240	2 x 150P10	CS2-5-240	HCPK5
300	2 x 200P10	CS2-5-300	HCPK5

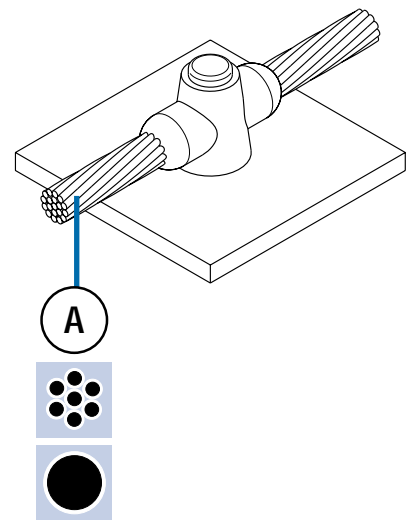

CS3

Cable to steel surface and pipe

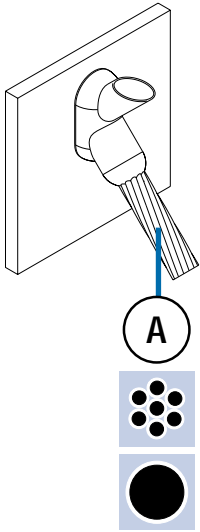

A mm ²				MINI 	
16*	45P10	CS3-4-16	HCPK4	CS3-3-16	HCPK3
25	45P10	CS3-4-25	HCPK4	CS3-3-25	HCPK3
35	45P10	CS3-4-35	HCPK4	CS3-3-35	HCPK3
8mm Ø	65P10	CS3-4-8SC	HCPK4	CS3-3-8SC	HCPK3
50	65P10	CS3-4-50	HCPK4	CS3-3-50	HCPK3
10mm Ø	90P10	CS3-4-10SC	HCPK4	CS3-3-10SC	HCPK3
70	90P10	CS3-4-70	HCPK4	CS3-3-70	HCPK3
95	115P10	CS3-4-95	HCPK4	CS3-3-95	HCPK3
120	115P10	CS3-4-120	HCPK4	CS3-3-120	HCPK3
150	115P10	CS3-4-150	HCPK4	CS3-3-150	HCPK3
185	200P10	CS3-4-185	HCPK4	-	-
240	200P10	CS3-4-240	HCPK4	-	-
300	250P10	CS3-4-300	HCPK4	-	-

* 1 x S103

CS7

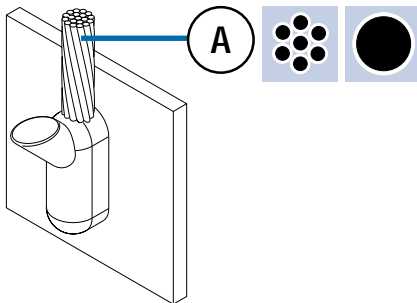

A mm ²				MINI 	
16*	65P10	CS7-4-16	HCPK4	CS7-3-16	HCPK3
25	65P10	CS7-4-25	HCPK4	CS7-3-25	HCPK3
35	65P10	CS7-4-35	HCPK4	CS7-3-35	HCPK3
8mm Ø	90P10	CS7-4-8SC	HCPK4	CS7-3-8SC	HCPK3
50	90P10	CS7-4-50	HCPK4	CS7-3-50	HCPK3
10mm Ø	150P10	CS7-4-10SC	HCPK4	-	-
70	150P10	CS7-4-70	HCPK4	-	-
95	200P10	CS7-5-95	HCPK4	-	-
120	200P10	CS7-5-120	HCPK4	-	-
150	250P10	CS7-5-150	HCPK4	-	-
185	2 x 150P10	CS7-9-185	HCPK4	-	-
240	2 x 150P10	CS7-9-240	HCPK4	-	-
300	2 x 200P10	CS7-10-300	HCPK5	-	-

* 1 x S103

CS8

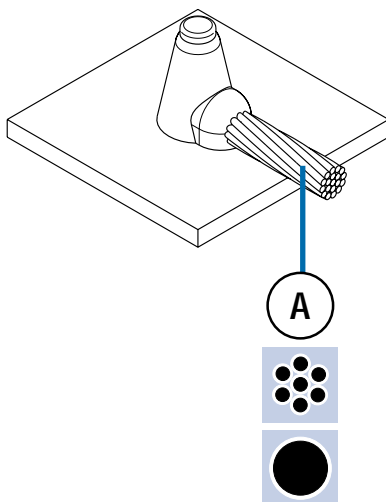



A mm ²			
16*	45P10	CS8-2-16	HCPK2
25	45P10	CS8-2-25	HCPK2
35	45P10	CS8-2-35	HCPK2
8mm Ø	45P10	CS8-2-8SC	HCPK2
50	45P10	CS8-2-50	HCPK2
10mm Ø	65P10	CS8-2-10SC	HCPK2
70	65P10	CS8-2-70	HCPK2
95	90P10	CS8-2-90	HCPK2
120	115P10	CS8-4-120	HCPK4
150	150P10	CS8-4-150	HCPK4
185	200P10	CS8-4-185	HCPK4
240	200P10	CS8-4-240	HCPK4
300	250P10	CS8-4-300	HCPK4

* 1 x S103





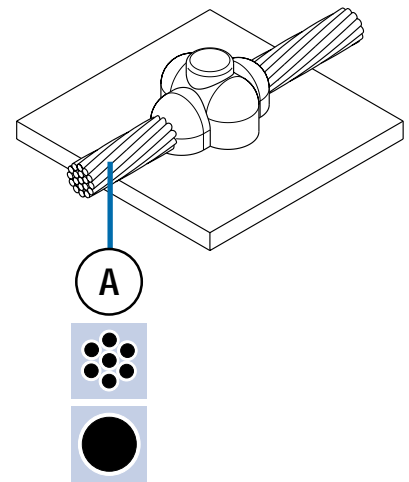

Cable to steel surface and pipe

CS9

A mm ²			
16*	45P10	CS9-2-16	HCPK2
25	45P10	CS9-2-25	HCPK2
35	45P10	CS9-2-35	HCPK2
8mm Ø	90P10	CS9-4-8SC	HCPK4
50	90P10	CS9-4-50	HCPK4
10mm Ø	115P10	CS9-4-10SC	HCPK4
70	115P10	CS9-4-70	HCPK4
95	115P10	CS9-4-95	HCPK4
120	150P10	CS9-4-120	HCPK4
150	200P10	CS9-4-150	HCPK4
185	250P10	CS9-4-185	HCPK4
240	2 x 150P10	CS9-5-240	HCPK5





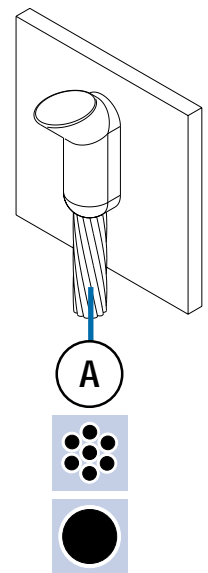

CS25

A mm ²				MINI 	
16*	45P10	CS25-4-16	HCPK4	CS25-3-16	HCPK3
25	45P10	CS25-4-25	HCPK4	CS25-3-25	HCPK3
35	45P10	CS25-4-35	HCPK4	CS25-3-35	HCPK3
8mm Ø	65P10	CS25-4-8SC	HCPK4	CS25-3-8SC	HCPK3
50	65P10	CS25-4-50	HCPK4	CS25-3-50	HCPK3
10mm Ø	90P10	CS25-4-10SC	HCPK4	-	-
70	90P10	CS25-4-70	HCPK4	CS25-3-70	HCPK3
95	115P10	CS25-4-95	HCPK4	-	-
120	115P10	CS25-4-120	HCPK4	-	-
150	150P10	CS25-4-150	HCPK4	-	-
185	200P10	CS25-4-185	HCPK4	-	-
240	200P10	CS25-4-240	HCPK4	-	-
300	250P10	CS25-4-300	HCPK4	-	-



CS27

A mm ²				MINI 	
16*	45P10	CS27-4-16	HCPK4	CS27-3-16	HCPK3
25	45P10	CS27-4-25	HCPK4	CS27-3-25	HCPK3
35	45P10	CS27-4-35	HCPK4	CS27-3-35	HCPK3
8mm Ø	65P10	CS27-4-8SC	HCPK4	CS27-3-8SC	HCPK3
50	65P10	CS27-4-50	HCPK4	CS27-3-50	HCPK3
10mm Ø	115P10	CS27-4-10SC	HCPK4	-	-
70	115P10	CS27-4-70	HCPK4	-	-
95	150P10	CS27-4-95	HCPK4	-	-
120	150P10	CS27-4-120	HCPK4	-	-
150	200P10	CS27-5-150	HCPK5	-	-
185	250P10	CS27-5-185	HCPK5	-	-
240	2 x 150P10	CS27-5-240	HCPK5	-	-
300	2 x 200P10	CS27-5-300	HCPK5	-	-

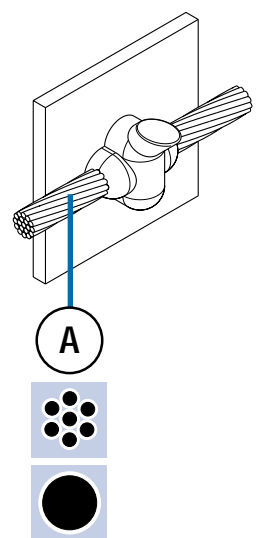
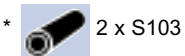

CS32

Cable to steel surface and pipe

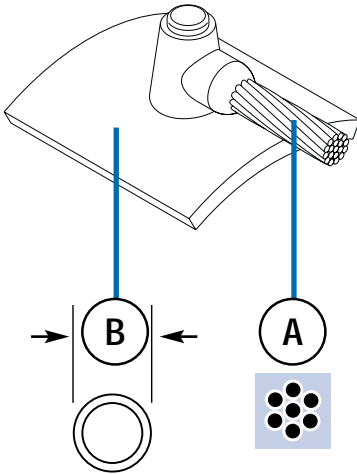

A mm ²	B mm Ø				
2.5	<125	15P10	CS32-1-2.5-A	HCPK1	1 x S105
2.5	>125	15P10	CS32-1-2.5-B	HCPK1	1 x S105
4	<125	15P10	CS32-1-4-A	HCPK1	1 x S105
4	>125	15P10	CS32-1-4-B	HCPK1	1 x S105
6	<125	15P10	CS32-1-6-A	HCPK1	1 x S105
6	>125	15P10	CS32-1-6-B	HCPK1	1 x S105
10	<125	25P10	CS32-1-10-A	HCPK1	1 x S102
10	>125	25P10	CS32-1-10-B	HCPK1	1 x S102
16	<125	45P10	CS32-2-16-A	HCPK2	1 x S103
16	>125	45P10	CS32-2-16-B	HCPK2	1 x S103
25	<70	25P10	CS32-1-25-C	HCPK1	-
25	70 - 165	25P10	CS32-1-25-D	HCPK1	-
25	>165	25P10	CS32-1-25-E	HCPK1	-
35	<70	45P10	CS32-2-35-C	HCPK2	-
35	70 - 165	45P10	CS32-2-35-D	HCPK2	-
35	165 - 250	45P10	CS32-2-35-F	HCPK2	-
35	>250	45P10	CS32-2-35-G	HCPK2	-
50	<70	45P10	CS32-2-50-C	HCPK2	-
50	70 - 165	45P10	CS32-2-50-D	HCPK2	-
50	165 - 250	45P10	CS32-2-50-F	HCPK2	-
50	>250	45P10	CS32-2-50-G	HCPK2	-
70	<70	65P10	CS32-2-70-C	HCPK2	-
70	70 - 165	65P10	CS32-2-70-D	HCPK2	-
70	165 - 250	65P10	CS32-2-70-F	HCPK2	-
70	>250	65P10	CS32-2-70-G	HCPK2	-

CS34

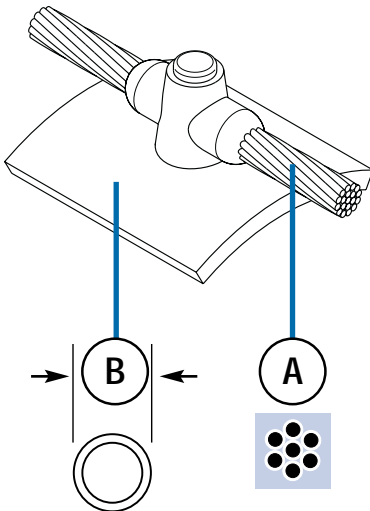

A mm ²	B mm Ø				
2.5	<125	15P10	CS34-2-2.5-A	HCPK2	2 x S105
2.5	>125	15P10	CS34-2-2.5-B	HCPK2	2 x S105
4	<125	15P10	CS34-2-4-A	HCPK2	2 x S105
4	>125	15P10	CS34-2-4-B	HCPK2	2 x S105
6	<125	15P10	CS34-2-6-A	HCPK2	2 x S105
6	>125	15P10	CS34-2-6-B	HCPK2	2 x S105
10	<125	32P10	CS34-2-10-A	HCPK2	2 x S102
10	>125	32P10	CS34-2-10-B	HCPK2	2 x S102
16	<125	45P10	CS34-2-16-A	HCPK2	2 x S103
16	>125	45P10	CS34-2-16-B	HCPK2	2 x S103
25	<70	32P10	CS34-2-25-C	HCPK2	-
25	70 - 165	32P10	CS34-2-25-D	HCPK2	-
25	>165	32P10	CS34-2-25-E	HCPK2	-
35	<70	45P10	CS34-2-35-C	HCPK2	-
35	70 - 165	45P10	CS34-2-35-D	HCPK2	-
35	165 - 250	45P10	CS34-2-35-F	HCPK2	-
35	>250	45P10	CS34-2-35-G	HCPK2	-
50	<70	65P10	CS34-2-50-C	HCPK2	-
50	70 - 165	65P10	CS34-2-50-D	HCPK2	-
50	165 - 250	65P10	CS34-2-50-F	HCPK2	-
50	>250	65P10	CS34-2-50-G	HCPK2	-